

Dodge County Highway Department

MAIL BOX POST APPLICATION

C.S.A.H. _____

County _____

Township _____

Village _____

Print or type application. Fill out application and mail to Dodge County Highway Department, P.O. Box 370, Dodge Center, MN 55927. Ph: 507-374-6694 Fax: 507-374-2552

Name of Applicant _____

Address _____

City _____

State MN _____

Zip _____

Telephone No. _____

Work No. _____

I, We, the undersigned, herewith make application for permission to provide and install one (1) swivel mail box post at the above address. It is agreed that all work will be done to the satisfaction of the Dodge County Highway Department. It is further agreed that no work in connection with this application will be started until the application is approved and the request for the mail box post has been paid in full by the above applicant in the amount of \$125.00. This fee amount included materials (excluding the mailbox), tax, and the installation. Not installed, the fee would be \$70.00 (including tax) for materials (excluding the mailbox.). It is understood that the Dodge County Highway Department has up to ten (10) working days to complete this request. (See on back of application for the description of the "Recommended Steel Mail Box Support Post")

_____ Date

_____ Signature of Applicant

FOR COUNTY USE ONLY:

Upon approval of the application a fee in the amount of \$ _____ will be required before materials and/or installation is completed.

Personal, Cashier's or Certified Check No. _____

CASH _____

This payment was made on the _____ day of _____, 20 _____, by

_____ (Name)

APPROVED BY:

Application Issued by: _____

_____ County Engineer

_____ Date

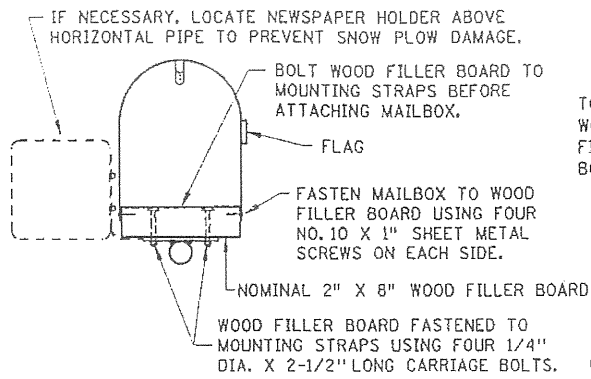

SECTION A-A

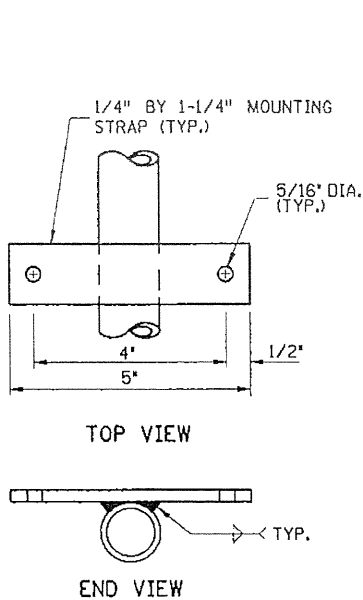

MOUNTING STRAP DETAIL

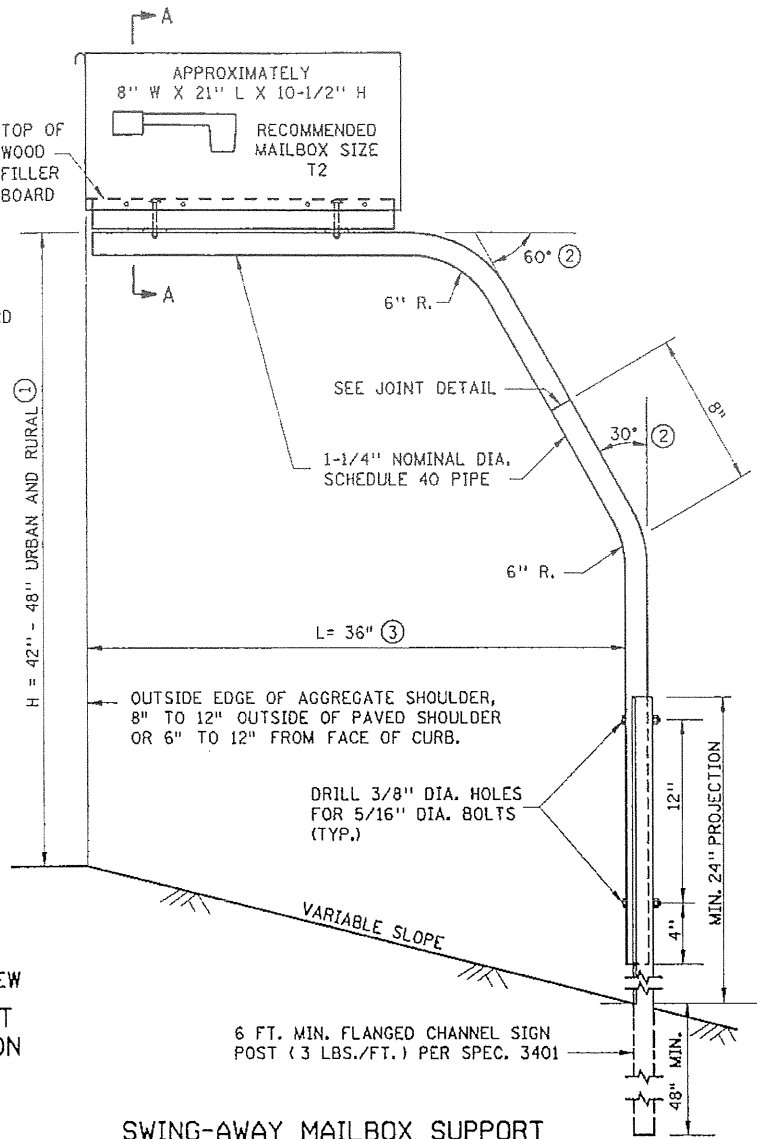
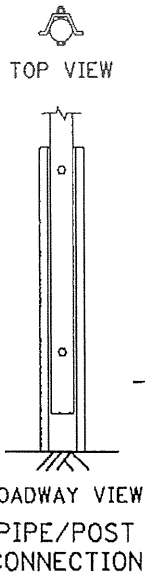

SWING-AWAY MAILBOX SUPPORT

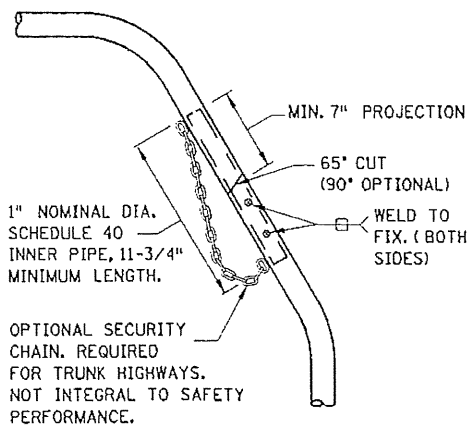

JOINT DETAIL

NOTES:

MAILBOX LOCATIONS SHOULD BE STAKED BEFORE INSTALLATION FOR PROPER HEIGHT AND DISTANCE FROM THE ROADWAY. ONCE STAKED, THE INSTALLER MUST NOTIFY THE ENGINEER AND THE POST OFFICE. THE ENGINEER AND THE POSTMASTER SHALL APPROVE THE STAKED LOCATIONS PRIOR TO FINAL INSTALLATION.

THE MINIMUM SPACING (CENTER TO CENTER) BETWEEN MULTIPLE MAILBOX SUPPORTS SHALL BE EQUAL TO THE HEIGHT OF THE MAILBOX SUPPORT.

OTHER MAILBOX SUPPORT DESIGNS MAY BE USED IF THEY SATISFY NCHRP REPORT 350 CRITERIA IN ACCORDANCE WITH FHWA ACCEPTANCE LETTER, MEET MINNESOTA RULES 8818 AND U.S. POST OFFICE RECOMMENDATIONS AND ARE IN COMPLIANCE WITH MN/DOT REQUIREMENTS WHICH MAY INCLUDE THE FOLLOWING (REQUIRED ON TRUNK HIGHWAYS):

- PIPE SHALL CONFORM TO SPEC. 3362, SCHEDULE 40 OF ASTM A53/A53M.
- ALL FASTENERS SHALL CONFORM TO SPEC. 3391.
- PIPES, POST AND OTHER STEEL COMPONENTS SHALL BE GALVANIZED PER SPEC. 3392.

THE CONTRACTOR SHALL SEND THE SHOP DRAWINGS TO THE ENGINEER FOR APPROVAL. FOR QUESTIONS REGARDING DESIGN ELEMENTS AND BREAKAWAY FEATURES, CONTACT THE DESIGN STANDARDS UNIT.

- ① ANY CHANGE IN HEIGHT (H) MUST BE APPROVED BY LOCAL POSTMASTER.
- ② 45° BENDS MAY BE USED AS AN OPTION.
- ③ A 48" OR 53" CANTILEVER LENGTH (L) MAY BE USED AS AN OPTION FOR NON-TRUNK HIGHWAY USE.

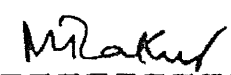
APPROVED <u> JUNE 1, 2007 </u>  STATE DESIGN ENGINEER	STATE OF MINNESOTA DEPARTMENT OF TRANSPORTATION MAILBOX SUPPORT SWING-AWAY TYPE	SPECIFICATION REFERENCE 3362 3391 3392 3401	STANDARD PLATE NO. 9350A
--	---	--	--

8818.0300 PROHIBITED MAILBOX STRUCTURES; EXCEPTIONS.

Subpart 1. **Unlawful installations and supports.** The following mailbox installations and supports are declared to be a public nuisance, a road hazard, and a danger to the health and safety of the traveling public if located along a street or highway having a speed limit of 40 miles per hour or greater:

- A. an installation that contains more than one vertical support;
- B. a single support containing more than two mailboxes;
- C. a wooden support with a cross-sectional area greater than 16 square inches at any above-ground point along the support (for example, the maximum allowable square and round support dimensions are four inches by four inches and 4.5 inches in diameter, respectively), except that larger wooden supports are acceptable if, at a height four inches above the ground, the support cross-sectional area is altered in some fashion so as to reduce the cross-sectional area at that point to 16 square inches or less;
- D. a metal support of a weight of four pounds per foot or more for any one foot of vertical measurement above ground (for example, a standard steel pipe of up to two inches inner diameter would be acceptable), except that larger metal supports are acceptable if, within the first three inches above ground the metal support is less than four pounds per foot (less than one pound for the three-inch length);
- E. a mailbox that is not acceptable for delivery of mail by the United States Postal Service;
- F. adjacent mailbox installations whose respective supports are spaced closer than 30 inches, as measured from center of support to center of support;
- G. neighborhood delivery and collection box units, whether or not United States Postal Service approved;
- H. a support comprised of material other than solely wood or metal that either exceeds 16 square inches in total cross-sectional area at a height four inches above ground or is of a weight of four pounds per foot or more for any one foot of vertical measurement above ground, unless within the first three inches above ground the support is less than four pounds per foot (less than one pound over the three-inch distance). Examples of such nonconforming supports could include supports such as filled milk cans, brick structures, plows, and concrete-filled pipe; and
- I. an installation, whether a support or closed mailbox, that encroaches the usable roadway or its airspace.

Subp. 2. **Exceptions.** Notwithstanding subpart 1, mailbox installations that are documented to have passed an accredited crash test are acceptable. An accredited crash test is considered to be a test conducted in accordance with procedures described in the most recent National Cooperative Highway Research Program report, "Recommended Procedures for the Safety Performance Evaluation of Highway Appurtenances," published by the Transportation Research Board, National Academy of Sciences, 2101 Constitution Avenue N.W., Washington, D.C. 20418. This report and future revisions of this report are incorporated by reference. The report is not subject to frequent change and is available to the public at the State Law Library, Judicial Center, 25 Constitution Avenue, St. Paul, Minnesota 55155, and through the Minitex interlibrary loan system.

STAT AUTH: MS s [169.072](#)